



design | 3D | materials lists

20
26

SOFTPLAN
ARCHITECTURAL DESIGN SOFTWARE

SoftPlan 2026 Major Features

3D Path Tracing

SoftPlan 2026 continues SoftPlan's tradition of significantly advancing 3D presentation with each new version. In this release, SoftPlan has introduced the ability to apply PBR (physically based rendering) textures to 3D surfaces. PBR texturing is a technique that greatly enhances the way 3D modeling is created and visualised in SoftPlan by simulating how light interacts with materials in a way that mimics reality. As various lighting methods are added to the model, PBR textures are able to consistently respond to these changes to achieve superior looking 3D designs.



PBR Textures

Along with the new ability to apply PBR textures to the 3D model, this release also includes a simple tool for directly importing PBR texture files from the web into SoftPlan. By selecting this command, SoftPlan opens a window to **the Lightbeams website where an expansive library of high-quality PBR textures can be explored and downloaded for use.** Once downloaded, the texture is added to a folder in SoftPlan where it can be applied to a 3D surface through a quick Surface Edit. SoftPlan's new PBR import tool provides an ever-expanding level of customisation for creating highly realistic exteriors and interiors in 3D.



SoftPlan 2026 Major Features

Roof Material Profiles

SoftPlan 2026 includes a setting to apply detailed profile styles to roof materials which allows SoftPlan to generate more realistic-looking roofs in 3D. Using this new setting, a Profile, Architectural Shingle, or Cedar Shake style can be added to the roof material and then further customised by increasing the texture count. Please note that generating complex roof materials in 3D is very resource-intensive which causes longer rendering times.



Import Sketchup Symbols Directly into SoftPlan 3D Models

Adding to SoftPlan's extensive selection of 3D customisation tools, SoftPlan 2026 includes the ability to import SketchUp symbols directly into the 3D model. Selecting this command opens SketchUp's 3D Warehouse in a browser window where 3D symbols can be quickly located and downloaded as SketchUp files. Once the file is downloaded, SoftPlan automatically imports the 3D symbol into a "3D Downloads" library and creates a 2D symbol counterpart for use in the project.



Multiple Building Options Active at One Time

SoftPlan 2026 makes it easier to manage variations in a building plan by including the ability to have multiple Building Options active at the same time. In past versions, only one building option could be active at a time which created the need

Option	Visible	Lock	Fade	Use Item(s) Color	Color	Use Item(s) Linestyle	Linestyle	Pen	# in Model	# in Drawing	Comment
Default	<input checked="" type="checkbox"/>	Manual	<input type="checkbox"/>	<input checked="" type="checkbox"/>		<input checked="" type="checkbox"/>		Default	2	2	
3 car garage	<input type="checkbox"/>	Manual	<input type="checkbox"/>	<input checked="" type="checkbox"/>		<input checked="" type="checkbox"/>		Default	0	0	
4 car garage	<input type="checkbox"/>	Manual	<input type="checkbox"/>	<input checked="" type="checkbox"/>		<input checked="" type="checkbox"/>		Default	0	0	
office	<input type="checkbox"/>	Manual	<input type="checkbox"/>	<input checked="" type="checkbox"/>		<input checked="" type="checkbox"/>		Default	0	0	
office exterior entry	<input type="checkbox"/>	Manual	<input type="checkbox"/>	<input checked="" type="checkbox"/>		<input checked="" type="checkbox"/>		Default	0	0	

to edit items and connect them to all the other desired building options. Now multiple building options can be selected at once and activated so that drawn items are automatically added to those building options as needed.

Mode Specific Layer Settings

SoftPlan's Layer feature allows the user to define the displayed appearance of different items on a drawing and control their visibility while designing. Previously, changing the display properties of items on a layer would affect the appearance of those items in all drawing modes. Now in SoftPlan 2026, the Layer functionality includes an option to configure a layer's display properties differently for each drawing mode, extending the flexibility needed to create comprehensive house plans.

Name	Lock	Fade	Use Item(s) Color	Color	Use Item(s) Linestyle	Linestyle	No Print	Pen	Comment
Default	<input type="checkbox"/>	<input type="checkbox"/>	<input checked="" type="checkbox"/>		<input checked="" type="checkbox"/>		<input type="checkbox"/>	Default	
Layer 1	<input type="checkbox"/>	<input type="checkbox"/>	<input checked="" type="checkbox"/>		<input checked="" type="checkbox"/>		<input type="checkbox"/>	Default	
Layer 2	<input type="checkbox"/>	<input type="checkbox"/>	<input checked="" type="checkbox"/>		<input checked="" type="checkbox"/>		<input type="checkbox"/>	Default	
Layer 3	<input type="checkbox"/>	<input type="checkbox"/>	<input checked="" type="checkbox"/>		<input checked="" type="checkbox"/>		<input type="checkbox"/>	Default	
Layer 4	<input type="checkbox"/>	<input type="checkbox"/>	<input checked="" type="checkbox"/>		<input checked="" type="checkbox"/>		<input type="checkbox"/>	Default	
Layer 5	<input type="checkbox"/>	<input type="checkbox"/>	<input checked="" type="checkbox"/>		<input checked="" type="checkbox"/>		<input type="checkbox"/>	Default	
Layer 6	<input type="checkbox"/>	<input type="checkbox"/>	<input checked="" type="checkbox"/>		<input checked="" type="checkbox"/>		<input type="checkbox"/>	Default	
Layer 7	<input type="checkbox"/>	<input type="checkbox"/>	<input checked="" type="checkbox"/>		<input checked="" type="checkbox"/>		<input type="checkbox"/>	Default	
Layer 8	<input type="checkbox"/>	<input type="checkbox"/>	<input checked="" type="checkbox"/>		<input checked="" type="checkbox"/>		<input type="checkbox"/>	Default	
Layer 9	<input type="checkbox"/>	<input type="checkbox"/>	<input checked="" type="checkbox"/>		<input checked="" type="checkbox"/>		<input type="checkbox"/>	Default	
Layer 10	<input type="checkbox"/>	<input type="checkbox"/>	<input checked="" type="checkbox"/>		<input checked="" type="checkbox"/>		<input type="checkbox"/>	Default	

SoftPlan 2026 Major Features

Roof Edge Reference

A major change to the Add Roof Edges command allows the appearance of new roof edges to be controlled without needing to reference a wall or beam. Once added, editable roof properties such as gutters, gable corners, soffits, and fascia can all be modified on these individual roof edges as needed. This functionality is also applied to any new roof edges that are created by cutting holes in a roof edge.

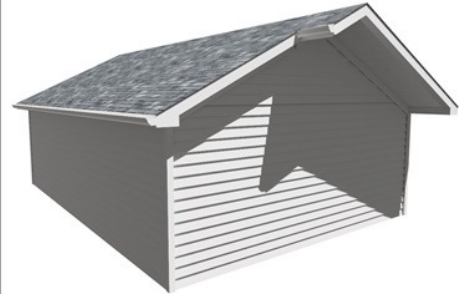
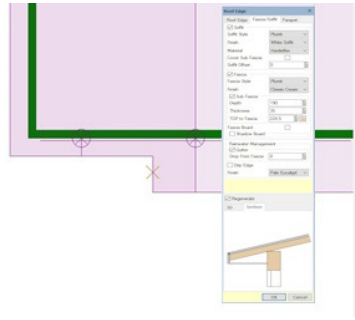

Google Earth Satellite Image

After importing a Google Earth satellite image of a site into SoftPlan, this release includes a new function for mapping the satellite image onto a property polygon as a texture in the 3D model. Once the satellite texture has been assigned to the 3D property through a Surface Edit, it then automatically updates to accommodate any changes to the site plan.



Door Layout Tool

In this release, SoftPlan has completely overhauled door customisation by developing a parametric system for defining the layouts of doors. Using the new Door Layout menu, the opening properties of any door shape can be customised, and the rail, stile, and other part dimensions can be fixed to maintain their size when the overall size of the door is modified. This menu also includes an intuitive grid control for adding and modifying the parts of the door such as glazing, top shapes, panels, and even 3D symbols. Using the Door Layout menu, greatly detailed doors can be created and saved into the system library for future use.

Roof Options Lock

SoftPlan 2026 introduces the ability to lock certain roof settings to easily meet specific design requirements. With this change, various roof values (Pitch, Overhang, Heel Height, Seat Cut, Butt Cut, and TOP to Fascia) can be locked so that modifying other roof options will not affect the locked value. For example, a roof that uses different overhangs, pitches, and heel heights can easily maintain a common fascia line without issue.

Combine Like Walls

When a wall is broken into two or more wall lengths, or when two walls of the same type are initially drawn end to end, there may be a need to combine the multiple wall lengths into a single wall again. Using the new Combine Like Walls command, SoftPlan automatically locates the end points of neighboring walls of the same type and allows the user to combine the wall lengths into a single framed wall that maintains any existing openings.

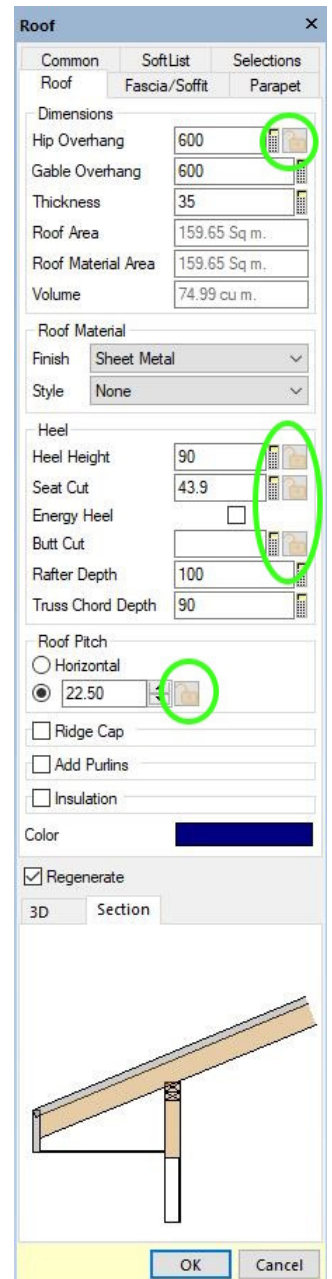

SoftPlan 2026 Major Features

Symbols and Solids Rotate in 3D

When editing a symbol or solid in SoftPlan 2026, a new 3D Rotation tab is available for specifying the pitch and roll angles of the object in 3D. The new 3D Rotation tab also includes display options for how the rotation settings of symbols and solids appear on the 2D floor plans.



Half-Open Stairways

Adding to SoftPlan's stair customisation tools, this release includes a right-click command to automatically clip a straight stair to a wall when the wall overlaps the stair's edge. Usable in both 2D and 3D, this command clips the stair to the visible wall edge while trimming and removing rail posts from any railings that touch or overlap the wall end.

Dashed Lines Below Grade on Elevations

SoftPlan 2026 includes a new option for automatically displaying lines below the grade to dashed when generating an elevation view and saving it as a SoftPlan drawing. By enabling this option, SoftPlan locates the grade of the project using either the Site Plan or the Auto Horizon and then generates the lines of the elevation drawing accordingly to help differentiate what is above and below the grade line.

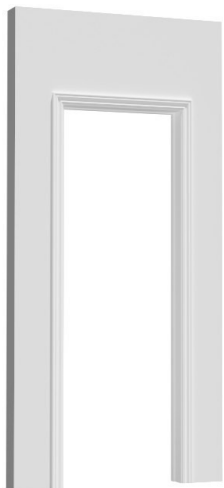
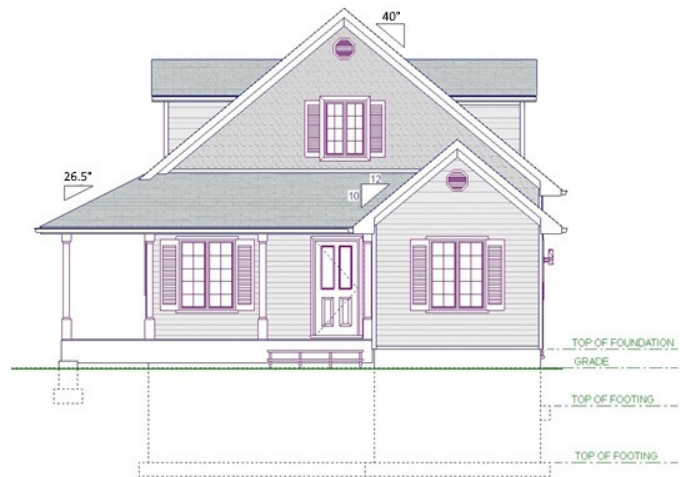

Opening Trim Reveal

Adding to the many changes to opening customisation in this version, SoftPlan 2026 includes an option for specifying the amount of opening frame not covered by trim. The Reveal value can be set from the system-level down to the individual opening, providing a way to achieve a precise offset for the gap between the interior trim and the edge of the opening frame. Setting the Reveal value as needed allows for more accurate representations of openings throughout the 3D model.

Auto Dimension Improvements

In past versions of SoftPlan, selecting the Auto Dimension command could possibly cause the program to remove manually added extensions and dimensions from the plan while replacing existing exterior dimensions with new ones. Now in SoftPlan 2026, Auto Dimension can be used to update the plan and add any missing information without affecting manually added dimensions and extensions. Additionally, with the Auto Extension and Dimension option enabled in the System Options, the Auto Dimension tool won't affect manually added extensions and dimensions when changes are made to the drawing, such as placing additional windows that are automatically dimensioned.

SoftPlan version 2026 Detailed Features

3D

- 3D looks to the SoftPlan+ server automatically downloading any required textures that are not already present locally
- A live-editable option showing the number of passes for a Path Trace rendering is available on the Toolbar
- Artifacts that often displayed a blue glow around surfaces with transparent elements (tree leaves) have been removed
- Background Offset option added to Image (360 Photo) allowing the background image to be moved left/right/up/down behind the model
- DirectX 12 is used for all previews on Edit dialogs
- DirectX 12 is the default Renderer on all machines that have DirectX 12 capable hardware, the applies to all 3D modes, elevations, sections and interior elevations
- DirectX-12 Render to File size limit raised to 8192 x 6144 provided the video card can handle the additional size
- Displacement Mapping option added to PBR materials
- Download 3D command added *File>Import* within a 3D model, allows SketchUp files to be directly inserted in a SoftPlan 3D model
- Download PBR Texture command added to the File > Import menu in 3D, directly imports PBR textures into the correct format and file organisation
- Gradient added to Background options, transitions the background evenly between two specified colours
- Headlight added to DX-12 renderer, helpful on interiors before the light fixtures are added
- Limit on the number of passes for a path trace rendering increased. Increased number of passes reduces the "dottiness" that can appear, more prevalent on lighter coloured surfaces. Increased passes would be used instead of the "denoise" command. The increased speed of newer video cards makes this practical
- LP Brand colours added to Colour Swatch options
- New compression schemes employed to reduce the memory required when creating DirectX 12 renders
- Physically Based Rendering added to DX12
- Performance of edits in 3D improved
- Relief Depth added to DX12 Path Traced renderings
- Repeat Edit applies Deck Finish between Deck Bench, Deck Ledger Board, Deck Parting Board, Deck Ring Joist, Deck Joist and Deck Boards
- Room Names in Annotated Presentation Mode draw using the Room Label Colour configuration option
- Rotate Camera Counter Clockwise Around Focus at Key Frame command added to Animations
- Rotate Focus Counter Clockwise Around Camera at Key Frame command added to Animations
- Structural Posts extract in 3D Framing views
- Satellite Image option added to texture selection for Site Polygons, places a Google Maps Satellite image texture on the Site Polygon
- Symbol Triangle Count added to *Help>Information>Model*
- Time Estimate added to status bar for Path Trace renders

Area

- Each edge of an Area polygon has unique Wall Reference to Edge properties, one edge can reference outside of sheathing while another references outside of the brick
- Mask Label option added
- Paint Pattern column added to Area Schedule
- Polygon Drawing method selection added:
 - Manual Trace
 - Auto Trace Interior
 - Auto Trace Exterior
- When a new Area is placed via the Draw Select tool the "Wall Reference for Polygon" from the source Area is used

Beams

- A Beam moved up or down in 3D will maintain its slope
- Beams on a nonvisible Building Option do not appear in generated Wall Panel diagrams from Framing mode
- Fit Top of Beam options added:
 - Roof Plumb*
 - Roof Rake*
 - Roof Flush*
 - Ceiling Plum*
 - Ceiling Rake*
 - Ceiling Flush*
- Glulam Beam (Pressure Treated) material added
- Laminate Beam (Pressure Treated) material added
- Locate of a Beam is easier if there is a Post, Post Footing, and Beam in close proximity

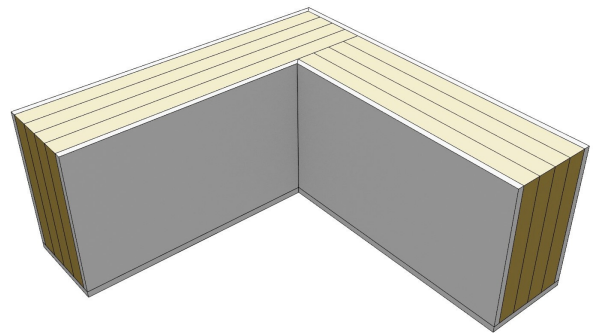

- Non-Bearing materials in Beam Definition join as in Wall Definition, wrapping structural Beam with non-structural materials, looks cleaner in the 3D model
- Radiused corners added to HSS Steel Beams
- Renumber Beam IDs command added to Notes

Building Options

- Column width reduced for # of Items in Model and Drawing
- Line style and Use Item(s) Line style options added
- Multiple Building Option can be active at one time

SoftPlan version 2026 Detailed Features

Cabinets

- Add Wall Cabinet command added to Edit or Right Click of a Base Cabinet, the new upper cabinet will match the width and style of the source cabinet
- Cabinets check against a wall's height and offset before adjusting sizes and adding countertops
- Leg Symbol options added to control placement; Set Per Leg or Set for Run, used for islands
- Obispo M. manufacturers cabinet handle library added
- Placement of large Cabinet Handles is improved, if a cabinet handle's 3D symbol extends above or below the cabinet face part it is automatically moved onto the cabinet face
- Part Comment field added to the Common Tab of Individual Cabinets, this is a comment field that lists in the Cabinet Schedule with the individual cabinet as opposed to Comment field that lists in the schedule with every Cabinet in a Cabinet Run
- Room Schedule ID (Room Numbers) column added to Cabinet Schedules
- Show Individual Cabinets option added to Cabinet Defaults
- Stack Above command added, places a wall cabinet directly above an existing wall cabinet: two rows of uppers
- Slim Panel Shaker Cabinet Style added



- Toe Kick material is separate from the cabinet material enabling it to be assigned differently
- Tolerance added to the Replace Cabinet command to reduce or eliminated small fillers that were added if the symbol was close in size to the cabinet being replaced
- Upper Cabinet placement improved more closely matches lowers; reducing unnecessary upper cabinet fillers

Ceilings

- Cedar added the default Finish options
- Ceilings can reference the outside material of a wall, on a porch roof for example
- Ceiling Outline Dashed option added to Visible Items, easy way to indicate sloped ceiling on the floor plan
- Floor Joist, Deck Joist and Ceiling Joist Hangers extract by default in 3D Framing Mode
- Generated ceiling framing drawing shows a hole for the Tray Ceiling
- Match Ceiling Planes command added, automatically offsets the start of a ceiling forming a continuous plane with neighboring ceiling.
- Profile option added to Strapping



- Repeat Edit can change the direction the Strapping runs
- Wall Heights in Ceiling Mode are colour coded, different height walls display in different colours

Decks

- Chamfer Bottom option added to Deck Railing Post
- Deck Framing Schedules option added to Visible Items
- Deck Materials Finish option default settings added
- Erasing Deck Benches is more predictable
- Floor Joist, Deck Joist and Ceiling Joist Hangers extract by default in 3D Framing Mode
- Is Full Tread option added to the Topmost Tread on Stairs and Deck Stairs, automatically aligning the top of the first tread with the top of the floor or deck
- Joist Hangers added to angled Deck Joists
- Joist Hanger Options added to Deck Options
- Repeat Edit applies Deck Finish between Deck Bench, Deck Ledger Board, Deck Parting Board, Deck Ring Joist, Deck Joist and Deck Boards in 3D
- Ring Joist added to Deck Joist Label option
- Swine Fence Railing added to defaults.
- The visibility of Deck Components can be managed through Visible Items, even when the Deck is assigned to a Layer

Details

- Chamfer Depth options added to Structural Slab section Detail
- Round Nosing option added to Stair Section Cross Section Detail.
- Section Detail added for Plywood

SoftPlan 2026 Detailed Features

Dimensions

- Arc Dimensions remain attached to Deck Polygons after Cleanup
- Auto Dimension no longer removes existing Extensions or Dimensions but rather automatically fills in any missing Extensions and Dimensions
- Dimensions and Extensions remain after using Block Cut or Insert Break on dimensioned or extended items

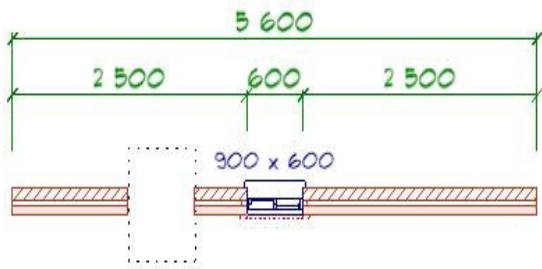
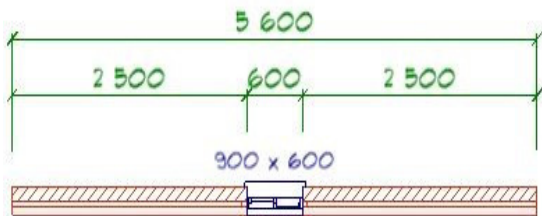

- Lines on an Overlay File are a source for the Distance command
- Lines from an Overlay File act as a source for the Set Distance Between command
- Preview added to the Set Distance Between command
- Placement of a Wall Thickness Dimension is not effected by the Enlarge Dimension Numbers option
- Room Dimension Size options added, select from Area, Width x Depth, Depth x Width or Longest by Shortest
- Round Nosing Stars Dimension easier in Cross Section

Electrical

- Ceiling Fans with lights added.
- Ceiling Outline Dashed lines display by default
- Electrical Symbol Extensions can easily be pulled from the construction point within the symbol, useful when centre locating fans and lights
- RBW Ceiling and wall lights manufacturer library added
- Roof Outline Dashed lines display by default
- Tesla wall charger added

Elevations & Sections

- Arrow Side option added to Cross Section Line, display one end, the other end or both ends
- Annotated Elevations, Sections, Interior Elevations generate larger models on older less advanced DX12 video hardware
- Order Cross Section Labels command added, reorders existing section letters
- DirectX 12 is the default Renderer on all machines that have DirectX 12 capable hardware, this applies to all 3D modes, elevations, sections and interior elevations.
- Saving an Elevation or Section culls hard edges from Symbols, Electrical, Opening and Cabinet Hardware
- Line type option added to Section Lines
- Pen options option added to Section Lines
- Show Partial Line option added, displays only the corners of the Section Line
- Show Dashed Lines Below Grade option added to Elevation Generation Options
- Symbolise Opening option added to Cross Section and Elevation Generation options. When selected Openings save as Symbols on elevations and sections, when not selected saved opening lines are placed on a Layer by type allowing Pens and Visibility to be controlled
- Style line formation for Openings on angled portions of elevations and sections improved

Extensions

- Extensions automatically find the Wall in the case where a Wall and a Rod & Shelf occupy the same corner
- Extensions can be added to Post Footings When using an extension tool and the cursor is not over an exceptionable items the 'Attention' dialog is replaced with an 'Attention' bubble that goes away on its own
- Extensions remain attached to a Box (shape) that is changed in size via an Edit of the Shape

Erase

- Type Erase allows Window and Door selection separately
- Type Erase of Framing Schedule removes Deck Framing Schedule

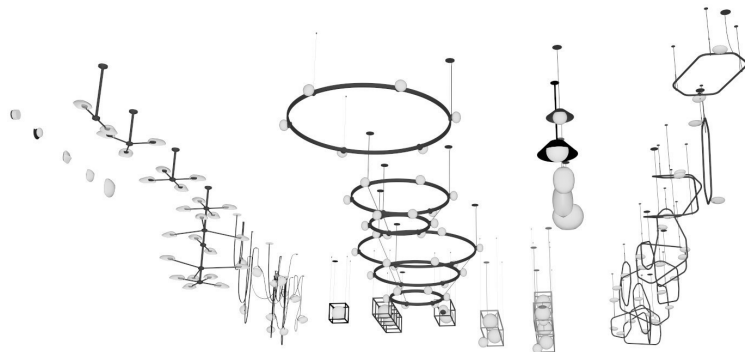

SoftPlan 2026 Detailed Features

File

- 2021 IECC Code option added to REScheck Export
- Client Information & Project Information are separate
- Contractor/Builder Information automatically saved to the system so that can be recalled for future projects
- County option added to Project Address, used for energy calculations
- Drawing, model and SoftList tabs that are not in use automatically hibernate, reducing the resources required by the application resulting in improved performance
- Export DWG files includes line types containing text
- Export of .FBX (Lumion) and .SKP (SketchUp) only include drawings from the current Visible Floors selection rather than the entire Model
- Export Metafiles as Images option added to PDF and Batch PDF Exports, by default Metafiles are exported as Metafiles, selecting this option reduces the file size of resulting PDF
- Export > Send To command includes custom 3D textures in the .zip file
- File menu has been reorganised to logically include former optional SoftPlan+ features
- Importing DWG files with elliptical arc segments improved
- Importing DWG files with items outside of the SoftPlan world improved
- Importing DWG files with unique line styles is improved
- In the event that SoftPlan can't access the SoftPlan+ server (there is no internet connection), SoftPlan quickly reverts to the local project files for the remainder of the session
- Note field added when creating a Project Revision, allows a comment on why the revision is being created
- Project Search, Cancel option added
- Project Search speed improved when searching a network
- Project Information: City field size increased
- Import and Export support added for SketchUp 2025
- Select Pages option added to Plan Set PDF Export
- Title Block Folder Location option added to System Options
- Recovery process automated on a drawing in the recovery folder
- Reload command added right click of a modified drawing contained on the model
- Size options added to Edit Image
- SketchUp Exports handle symbols with multiple textures

Interiors

- Baseboard position improved when placed over a non-structural Slab
- The butt ends of any partial Interior (Baseboard, Crown Mold, Chair Rail) automatically returns to the face of the wall resulting in a finished end
- Wallcovering placement on ends of Walls improved

Model

- Dormer Walls are ignored when creating an Auto Basement

Floor System

- Anchor Bolt option added to Sill Plate
- Double Top Plate option added to Floor Truss, Top Chord Bearing Truss and Top Chord Bottom Chord Bearing Truss
- Draw Select Ring Joist maintains number of joists
- Double Joist Under Parallel Walls option added, automatically places additional framing to carry walls above
- Floor System Hole recognises Single Joists when adding drywall
- Floor Truss Style Top Chord Bottom Chord added, the truss is top chord bearing at one end and bottom chord bearing at the other, frequently used for daylight basements
- Floor Joist, Deck Joist and Ceiling Joist Hangers extract by default in 3D Framing Mode
- Joist Hangers added to joists intersecting ring joist at angle
- Joist Set Label option added to Floor Joist Sets, automatically adds the joist size to an arrow that extends the length of the joists
- Overhang option added to Slab Edge, for Porch Slabs
- Ring Joists added to Floor Framing Label Visible Items
- Ring Joist Type OSB added
- Slab Insulation automatically adjusts to avoid a Wall Footing if Slab is placed directly on top of the Wall Footing
- Structural vs. Non-Structural Slabs are listed separately in Visible Items

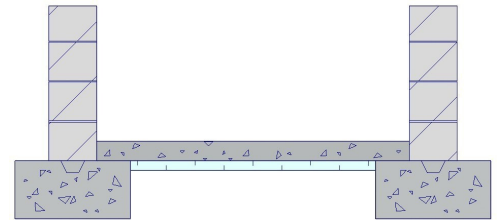

Move

- Extensions act to select items to be moved via the Centre Between Edges command
- The Count field on Copy and Block Copy dialog opens a dropdown selector

Interior Elevations

- Lines between coplanar cabinets hide automatically

Layers

- Layer setting for Fade, Colour, Pen. Line style. No Print and Pen are Mode specific
- Symbolise Opening option added to Cross Section and Elevation Generation options. When selected Openings save as Symbols on elevations and sections. When deselected saved opening lines are placed on Layer by type allowing Pens and Visibility to be controlled.
- The dropdown Mode selector displays customised Custom Mode names

SoftPlan 2026 Detailed Features

Openings

- 5 Panel doors added
- Beveled, Flat and Raised panel doors style added
- Cladding option added to Parametric Doors, this allows one side to be a different finish than the other side, previously only available on 3D symbol linked doors
- Dead Bolt option added to Opening Hardware
- Door Frames include a Doorstop in 3D model
- Extension Jamb option added to Door Frame
- Exterior Opening Trim adds correctly when Inset option is selected on an opening in a brick wall
- Flat Narrow Lever added to hardware
- Flooring and Threshold do not overlap in 3D
- Glazed Garage (Glass) Doors added to default libraries
- Hinges are reversed when a sliding window is reversed
- Header Width column option added to Opening Schedule
- Header Material dropdown selection can be opened multiple times in a session
- If Door Frame Thickness is edited the Rough Opening changes size and the Opening remain the same size

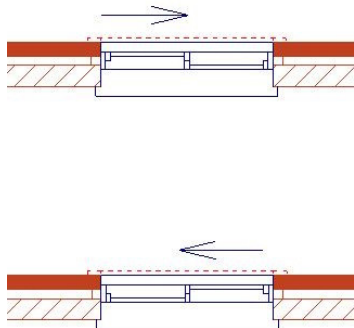

- Impact Glass option added
- Non-printable trim displays dashed lines representing both the inside and outside edges
- Openings or Unit Openings can be stacked on top of other without joining provided they are spaced more than a 300mm apart
- Openings that mulled together use the Cladding option from the single openings to allow the separate configuration of interior and exterior finishes

Panel Doors separated into libraries for Beveled, Flat Panel and Raised Panel

- The leaf size of the door panels is identical on a bifold door in plan view
- Use Interior Trim option added, allows interior trim to be placed on both sides of an interior bearing wall
- Repeat Edit applies changes made to Frame Thickness and Frame Width
- Reveal option added to Opening Trim Options, specifies the distance between the inside of the opening frame (reveal) and the inside of the opening trim
- Symbolise Opening option added to Cross Section and Elevation Generation options. When selected Openings save as Symbols on elevations and sections. When deselected saved opening lines are placed on Layer by type allowing Pens and Visibility to be controlled
- SHGC field reduced to show only 2 decimal places
- Symbol Tags added to Openings, used by the Search when placing windows and doors
- Tall Garage Door library added
- Top-hung blinds added to Opening Covering options, placed inside the window frame rather than extending past
- U-Value reduced to show only 2 decimal places
- Working on drawings with Opening IDs visible could be sluggish, performance is now improved

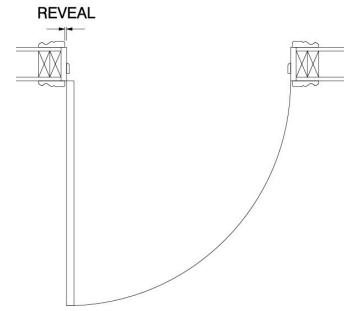

Miscellaneous



- Add Selection Box added to the Tools menu, add the items within a traced box to the current Selection Set
- Attach and Group options added to the Status Bar when the Modify command is used
- Colour settings store RGB values instead of index values, which helps minimize changes in item colours when drawings are opened in different locations from where they were created
- Double Fat Arrow style added to Arrow Shape
- Double-dash line style added
- Edit > Duplicate makes items that are located on different drawings identical
- Keyboard shortcut CTRL+T added for floating toolbar
- Remove Selection Box added to the Tools menu, removes the items within a traced box to the current Selection Set
- Speed of the Explode command increased when there are large numbers of resulting shapes

SoftPlan 2026 Detailed Features

Notes

- Deck Framing Schedules option added to Visible Items
- Grab handles display on a sorted column in a Schedule
- Note Direction -90 degrees value Repeat Edit & Duplicate
- Notes in Tables assigned to a Layer use the colour assignment of the Layer
- Header Width column option added to Opening Schedule
- Paint Pattern column added to Area Schedule
- Renumber Beam IDs command added
- Room Schedule ID (Room Numbers) column added to Cabinet Schedules
- Separate Font options added for: Schedule Content Font, Schedule Title Font, Schedule Heading Font

SEGMENTED POINTER

- The first segment of a Segmented Pointer stays horizontal

UNDERLINED CURVED NOTE

- Underline option added to curved notes

Paint

- Herringbone paint pattern added to Flooring folder
- Paint generation speed increased
- Paint options added to Site polygons
- Shade Paint toggle option added to the Status Bar

Plan Sets

- Annotated Elevations, Sections & Interior Elevations generate larger models on older, less advanced DX12 video hardware
- Custom Visibilities option added to Elevations, Sections and Interior Elevations in a Plan Set
- Export Metafiles as Images option added to PDF & Batch PDF Exports, by default Metafiles are exported as Metafiles, selecting this will reduce the file size of the resulting PDF
- Mask works properly on all justification types of Auto Scale Notes on Plan Sets
- Overlay visibility is maintained as Building Options enabled or disabled on a Plan Set
- Save of a PDF from a Plan Set remembers the location and the file name for subsequent PDF Exports
- Select Pages option added to Print and PDF Export allows individual pages to be selected from within the Plan Set
- Title Block Folder Location option added
- Trailing spaces prevented from Plan Set Group Prefix names
- Option added to automatically divide the page in two horizontally adding 2 Drawings to a Plan Set Page
- The small Cursor shortcut key (~) is enabled in Plan Sets

Print

- Select Pages option added to Plan Set Print
- A line assigned to a Layer will no longer ignore the Layer Pen if the Line is given a Width but no texture.

Posts

- Bigfoot footing tubes added to the Manufacturers library
- Canopy Bracket option added to Brace
- Craftsman Tall Base post definition added
- Post Pad added to Visible Items
- Champher option added to the Bracket portion of the Brace
- Roofs can directly reference the sides and ends of a Brace
- Extensions can be added to Post Footings
- Finish Option added to Post, allows the different items to be different colours
- If two posts are placed close to and beside each other the two footings are drawn as a single footing.
- Elevation option improved to automatically offset the Post, so it sits on the top of items decks or slabs.
- Inset Brace option added
- Post Capital Trim option added, places trim around the top of a post



SoftPlan 2026 Detailed Features

Railings

- 3D Surface Edit references the correct spindle finish
- Curved Transitions option added to Railings, places curved goosenecks and curved easings at railing transitions.
- Champher Bottom option added to Deck Railing Post
- Glass-no-rails Railing added to default Railing Library.
- Handrails and Guardrails list separate in SoftList
- Set Distance Between when used on the end of a railing adjusts the length of the railing rather than moving the railing



- Swine Fence Railing added to default Deck Railing Library

Roof

- 3D Textures on a Gable End align with textures on the wall below regardless of the direction that the wall was drawn
- Accent trusses with minimally deflected bottom chords are properly formed
- Corrected issue where Soffits that are overlap or are in close proximity to lower soffits could invert
- Cover Sub Fascia option added to Soffit, extends the Soffit to the meet the Fascia below the Sub Fascia
- Crickets improved when placed against larger gable end roofs.
- Default Soffit Material option added to Finishing Options
- Drip Edge option added to Rainwater Management section of the Fascia/Soffit tab
- Drop from Fascia option added, allows the Gutter to be lowered on the Fascia
- Extend option added to Gable Corners, lengthens the Fascia to cover the Gutter
- Fascia added to Roof Preview
- Fascia formation improved when a Bird Box is set to have a custom width
- Fascia on Flat Roofs improved
- Gable Corners formation improved on angled roof sections
- Gable Frieze properly forms when the roof is referenced to Beams, over a front porch for example
- Gable Frieze on angled walls improved
- Gable Vent width is editable when the Gable End is not being proved by the roof
- Independent Gable Corners properly reverse
- Inset Trim option enabled on Gable Vents
- Intersect Outside added to Roof Plane Style, automatically aligns the outside of a vertical intersect roof place with the outside of the wall material

- Roofs can directly reference the sides and ends of a Brace
- Roof Edge retains reference information when the visibility of the Wall, Beam, or Post it references is toggled on/off
- The time it takes to generate complicated roofs is reduced
- Match Roof Planes command works on Roof Edges with different Top of Top Plate to Bottom of Fascia values
- Performance improved when working on a Roof that contains an Accent Truss
- Roof Material Profile option added, models individual Clay Tiles or Standing Seam, roof material components in 3D
- Roof Options: Pitch, Overhang, Heel Height, Seat Cut, Butt Cut and Top to Fascia can be locked so that they remain constant while other values are changed, for example if the Top to Fascia value if locked the Fascia will remain level even if the Pitch were changed
- Saddle formation improved when the two roof planes forming the valley are pitched differently
- Soffit Material added to Roof Options default
- Soffit, Fascia and Bird Box formation on Log Wall improved
- Shadow Board added to Roof Preview
- Transition Boards can be successfully added to Multiple Floors Roofs
- Transition Boards form better on Roof Edges that also have Gable Frieze Boards or higher Heel Heights
- Unreferenced Roof Edges, added via Add Roof Edge or as a Hole, have the same edit properties as a Roof Edge that is referenced to a wall or a beam

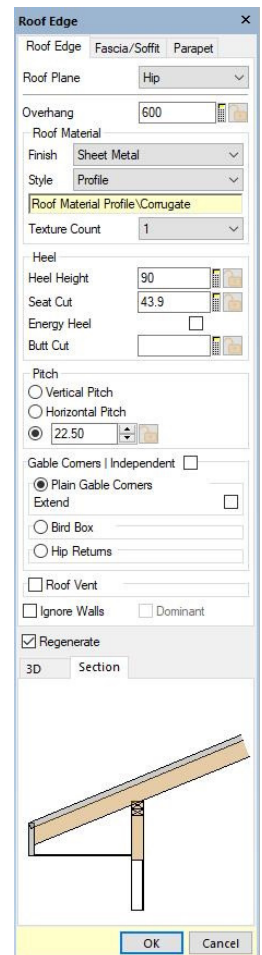

SoftPlan 2026 Detailed Features

SoftList

- *chamfer_depth* variable added to *Slab Component Slab Edge*
- Handrails and Grabrails list separate
- *has_impact_glass* variable added to Group Openings.
- *has_anchor* variable has been added to Joist Component Sill Plate.
- Timber: Price Per Each option added, allows Timber to be priced by the board
- Variables *object_width* & *object_length* added to Site Lines and Polyines.

Stairs

- Break option on curved stairs improved



- Clip Stair to Wall command added to the right click of a wall, removes the portion of a straight stair that overlaps the wall, modifying the shape of the stair
- Compound Stair Direction Arrow formation improved, eliminating double arrows
- Is Full Tread option added to the Topmost Tread on Stairs and Deck Stairs, automatically aligning the top of the first tread with the top of the floor or deck
- Round Nosing option added to Section Detail Stair
- Selecting File > System Options > Material Dimensions > Stair Options, changes made to the select the Default Stair Railing definitions only affect the current drawing template
- Stairs (On Other Floors) option added to Visible Items, allows stairs on lower level to display on the upper level, useful for Area and Room Modes

Symbols

- Copy Symbol is faster
- Generating the two dimensional representation of the 3D model is faster
- Linear drains added to the Kohler manufacturer library
- Symbols comprised as polygons will appear properly when set to display as Dashed or Hidden
- Vines added to Vegetation library
- Workshop folder added, tools.

Wall Framing

- Adjust can change the location of the Wall Framing ID
- Beams on a nonvisible Building Option do not appear in generated Wall Panel diagrams from Framing mode
- Block Move can be used to relocate an entire group of Structural Grid "bubbles"
- Blocking is improved if an Opening is placed high (or low) on a wall
- The length of a Shear Panel can be edited
- Top Plate added to Wall Panel dimensioning, adds the length of the Top Plate
- Wall Length option added to Wall Panel dimensioning

Walls

- Change Wall command defaults the Alignment option to Outside of Current Wall's Outermost Bearing Material
- Clip Stair to Wall command added to the right click of a wall, removes the portion of a straight stair that overlaps the wall, modifying the shape of the stair
- Combine Like Walls command added
- Drainage Mat material added for use in Wall Definition
- Footing intersect formation in 3D improved
- Footing Visibility options added separate from Wall Visibility
- Independent option added to End Treatments, allows end options to more easily be edited concurrently
- Profiled wall materials on coplanar walls (stacked), align in the 3D model
- Sloped Footing Base option works with a single step in the wall height
- Splash/Trim Board intersect improved
- Wall Materials added for siding: Siding-Cedar, Siding-Cement, Siding-Metal, Siding-Vinyl , Siding-Wood

web3d

- Roof display option added
- web3d in 2026 uses a more advanced web rendering system: webgpu

Zoom

- Zoom Extents acts as expected when Add Text is selected on a Dimension, but no text is entered.
- Zoom speed increased on drawings including large images



SoftPlan+ is a suite of server based tools that enrich the design process by providing users with the very best SoftPlan experience available.

free upgrades

SoftPlan subscribers always have access to the latest version SoftPlan.

online training content

access to the entire training library online

enhanced technical support

integrated support tickets

reView Viewer

a fully immersive 3D experience on PC, iPad, iPhone, or Android devices

PDF

Import & Export PDF files

reView

Import & Export SoftPlan reView files
panorama views

360° photo on Facebook and web pages

360° photos are interactive images can be panned and explored by anyone viewing them

Google

Import 3D terrain & satellite images directly from Google

SketchUp

Import from & export to SketchUp expanding the modeling options at your disposal

web3d

publish 3D models online where clients can tour their future homes using easy-to-use camera controls

premium manufacturer content

enhanced libraries including additional manufacturers:



Not all manufacturers libraries available in Australia.

SoftPlan+ cloud drive and services

SoftPlan+ web3d model viewer

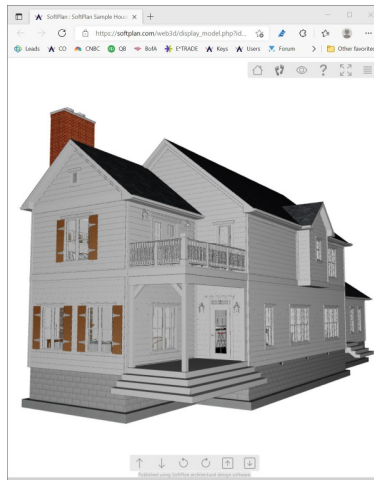

This feature allows you to publish 3D models directly to the web to be viewed by anyone you wish.

Once published, we create a link to your web3d page which we host on our site. Anyone you share this link with can view and explore your project without needing to download and install any additional software.

SoftPlan web3d models can be viewed and navigated on PC, phone, or tablet.



For existing SoftPlan users from any version

\$155 /month

SoftPlan+ monthly subscription includes access to SoftPlan 2026

Cadbuild Aust Pty Ltd
285 Dairy Rd
The Oaks
NSW, 2570



(02) 4657 1874
sales@cadbuild.com.au
www.cadbuild.com.au